

# Spin Feeding for Poultry

Collinson 

Economic, stress free feeding  
for broiler breeders that  
delivers uniform growth.

## Benefits

### Uniform growth:

Birds achieve point of lay at the same time. Feed is broadcast over a large area allowing all animals equal access to feed.

### Minimises Stress:

Reduced flocking minimises stress during feeding.

### Low Cost System:

Each dispenser can feed a large number of animals.

### Labour Saving:

Automatic Operation; spin feeder dispensers are replenished automatically.

### Easy to Use:

One central control unit, the amount of feed dispensed is simply adjusted by automatically batching set weights to each feeder or by varying Spinfeeder running time. Can be fully automated.

### Reliable Operation:

Premium quality components, Plasteel™ (plastic coated steel) frame with durable plastic body, clear cone and stainless steel internal parts.

### Personnel:

Not associated with feeding time therefore able to move more freely amongst the animals.

### Conforms to Welfare Code:

Encourages animals natural behaviour-freedom of movement promotes healthy condition.

### Easily Adapted to Most Types of Buildings:

Can be installed high up to avoid cleaning out machinery. Roof Mounted or Free Standing options available.

### Vermin Proof:

Hygienic easy clean materials assembled in a fully sealed system maintains feed freshness. Feeders may be detached from the roof mounted conveyer and lowered for easy cleaning.

### Safe Operation:

No risk of injury from moving parts, spinner plate is enclosed to deny personnel access. All cleaning is performed at ground level minimising work at height.



Silos  
Conveyors  
Feeders



After a long, long life Collinson Silos are 100% Recyclable

Broiler breeder performance can be influenced by many factors, feeding being a major consideration. Floor feeding offers certain advantages; increased flock uniformity, improved litter condition and the reduction of physical damage to legs.

The Collinson Spin Feeding System rapidly distributes feed over a large circular area, instantaneously providing an equal distribution of pellets, reducing flocking and competitive stress at feeding time.

It is the superior accuracy and consistently even feed distribution that is key to the success of the Collinson feeders.

## Specification

### Feed Capacity of 275kg @ 650kg/m<sup>3</sup>

- 150mm Extension Ring, add 75kg
- 300mm Extension Ring, add 150kg

### Self Weight (without feed)

- Roof Mounted, no outlet actuator: 60kg
- Roof Mounted, winchable: 80kg
- Floor Mounted: 80kg

### Feed Spread Pattern

- 20m Diameter Max
- Variable from 5m-20m
- 100% Coverage
- Even Distribution

### IP66 Electrical Ingress Protection (Power Washing)

- Spinner Motor
- Feed Outlet Actuator
- Enclosure (Inverter & I/O Board)

### 0.37kW Spinner Motor

### Auger Rotaflex 75mm

- 60mm o/d, 36mm i/d

### Weigher - see separate data sheet

- Max Weigher Chamber Capacity: 80kg @650kg/m<sup>3</sup>
- Max Weigher Chamber Load Volume: 0.123 m<sup>3</sup>
- Number of Load Cells: 2
- Load Cell Accuracy (% of Full Scale): 0.023%
- Weigh Chamber Lower Cone Construction: Clear Durable Plastic
- Weigh Chamber Cone Angle: 45° (for pelleted feed only)
- Outlet Actuator: 200mm / 24v (linear)
- IP Rating: IP54 (Dust / Water Splash)

## Spin Feeding is Versatile

Models are available to accommodate both new and existing buildings.



Free Standing



Roof Mounted Winchable



Roof Mounted

## How the Spin Feeder works

Pelleted feed is delivered to the storage hopper of the spin feeder by overhead conveyor. The feed can either be supplied in pre-weighed batches via a Collinson in-line electronic batch weigher or the spin feeder hopper can be filled to capacity and the feed metered on a volumetric basis by running the feeder for a fixed time span.

Each feeder has a variable drive motor which regulates the spread pattern of the feed, this can easily be adjusted to suit house size, Spin feeders are only suitable for pelleted feedstuffs with a maximum diameter of 6mm and a maximum length of 20mm.

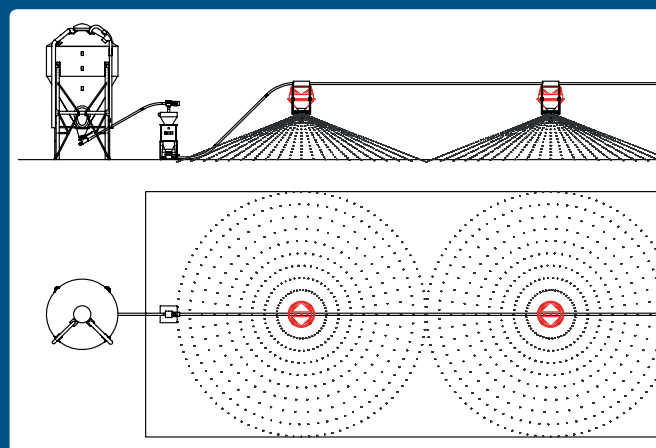

## Collinson plc

Riverside Industrial Park, Tan Yard Road,  
Catterall, Preston, Lancashire, PR3 OHP

T: 01995 606 451  
collinson.co.uk

Silos  
Conveyors  
Feeders

**Collinson**