

County Silo

Drive Under Range



SILO & GANTRY SYSTEM

A County silo elevated on the special heavy duty steel support gantry provides hygienic storage and fast and efficient delivery of feed directly in to your mixer wagon or trailer.

Simply drive or reverse under the gantry and open the pneumatic slide manually via the control panel on the leg, alternatively using the optional remote control operation from the warmth of your cab.

A range of models are available to provide excellent mass feed flow for free flowing pelleted products, wholegrains, meals and blends.

Special Features

- Volumes from 22.3m³ to 57.7m³
- Galvanised or Plasteel™ (Plastic coated galvanised steel) construction
- 60° or 67° discharge cone
- Smooth internal walls
- Pressure relief valve
- AutoVent
- FloView™ SafetyClean panel
- External, lockable filler pipe
- Heavy duty top filler bend (5mm wall thickness)
- Independent exhaust pipe
- Level indicators
- Crane lifting points
- Galvanised support structure designed to Eurocode 1, Part 1-4
- Heavy duty gantry; hot dipped galvanised for long life
- Drive under clearance; 4.3m
- Base Dimensions: (w)5.5m x (l)5.0m x (d)0.55m

NOTE: The pneumatic slide requires an air supply



Model Number	Cone Angle (deg)	Dia. (m)	Barrels	Overall Silo Height (m)	Capacity (m ³)	Meal 577 kg/m ³	Nuts 650 kg/m ³	Grain 693 kg/m ³	Base Size (m)	Important Notes * O/A Silo height is based on 4300mm gantry leg length. ** Silo capacity indicated is the true volume of the entire shell of the silo. Please allow extra capacity in the silo you chose to allow for: a) Variations in product density due to aeration of product during pneumatic silo filling. b) Variable density of the product due to manufacturing specification. c) Extra spare capacity. As a general rule we recommend you chose a silo with a minimum additional capacity of 20% over and above the size of loads you are planning to have delivered.
S1D4322P	60°	3.35m	1.0	9.55m	22.30m ³	12.87t	14.49t	15.45t	5.5 x 5.0 x 0.55m	
S1D4328P	60°	3.35m	1.5	10.16m	27.60m ³	15.93t	17.94t	19.13t	5.5 x 5.0 x 0.55m	
S1D4333P	60°	3.35m	2.0	10.76m	32.90m ³	18.98t	21.39t	22.80t	5.5 x 5.0 x 0.55m	
S1D4338P	60°	3.35m	2.5	11.37m	38.30m ³	22.10t	24.89t	26.94t	5.5 x 5.0 x 0.55m	
S1D4344P	60°	3.35m	3.0	11.97m	43.20m ³	24.93t	28.08t	29.94t	5.5 x 5.0 x 0.55m	
S1D4349P	60°	3.35m	3.5	12.58m	49.00m ³	28.27t	31.85t	33.96t	5.5 x 5.0 x 0.55m	
S1D4354P	60°	3.35m	4.0	13.18m	54.30m ³	31.33t	35.29t	37.63t	5.5 x 5.0 x 0.55m	
S4D4326P	67°	3.35m	1.0	11.01m	25.60m ³	14.77t	16.64t	17.74t	5.5 x 5.0 x 0.55m	
S4D4331P	67°	3.35m	1.5	11.61m	31.00m ³	17.89t	20.15t	21.48t	5.5 x 5.0 x 0.55m	
S4D4336P	67°	3.35m	2.0	12.22m	36.30m ³	20.95t	23.60t	25.16t	5.5 x 5.0 x 0.55m	
S4D4342P	67°	3.35m	2.5	12.82m	41.60m ³	24.00t	27.04t	28.83t	5.5 x 5.0 x 0.55m	
S4D4347P	67°	3.35m	3.0	13.43m	47.00m ³	27.12t	30.55t	32.57t	5.5 x 5.0 x 0.55m	
S4D4352P	67°	3.35m	3.5	14.03m	52.30m ³	30.18t	34.00t	36.24t	5.5 x 5.0 x 0.55m	
S4D4358P	67°	3.35m	4.0	14.64m	57.70m ³	33.29t	37.51t	39.99t	5.5 x 5.0 x 0.55m	

Tailoring your silo

Finish

For a long life, all Collinson silos are manufactured from high grade galvanised steel which gives a smart silver finish.

We also offer a choice of 6 coloured Plasteel finishes to suit aesthetic requirements. Match your buildings, fit in with the surroundings, or comply with requirements of your local planning authority.

A Plasteel coating also gives an additional layer of protection in coastal areas.



Gantry Specification

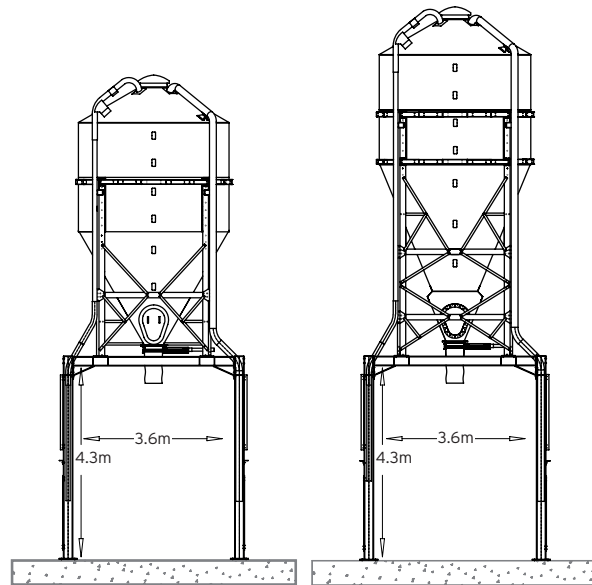
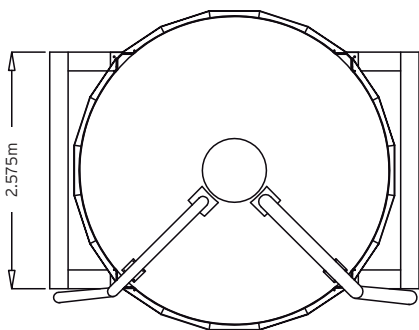

60° Discharge

67° Discharge